



Apollo Marine Specialties, Inc.

4227 Royal Street • New Orleans, LA 70117 • Phone: (504) 945-4849

EMBARKATION-DEBARKATION EQUIVALENT TO CHAIN LADDER

Marking Details:

- Apollo Marine Specialties, Inc., NOLA
- Adonic II
- Date of Manufacture in the following format:
DD/MM/YY
- USCG Approval Number 160.017/58/0
- USCG approved embarkation-debarkation
equivalent to chain ladder meets solas 1974, Chapter V
Regulation 17.

Description:

- Steps - Wood (Oak) have a diamond shaped grooves,
non-skid grit surface and painted a bright marine
orange. 4-1/2" wide, 1-3/16" thick, 20" long.
13-3/4" centers.
- Clamps - 6063 alloy aluminum.
- Rope suspension members - Synflex 3/4"
Poly-Plus. Tested to 2,000 lbs.

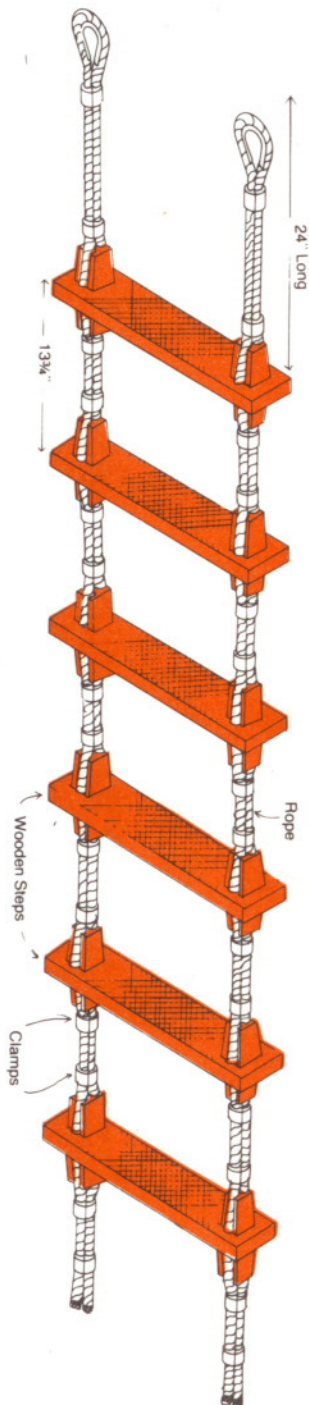

EMBARKATION-DEBARKATION EQUIVALENT TO
CHAIN LADDER CLASSIFIED BY
UNDERWRITERS LABORATORIES, INC.
IN ACCORDANCE WITH USCG REGULATION
TITLE 46 CHAPTER 1 PART 160.017

